

GL A1 TECHNICAL SPECIFICATIONS

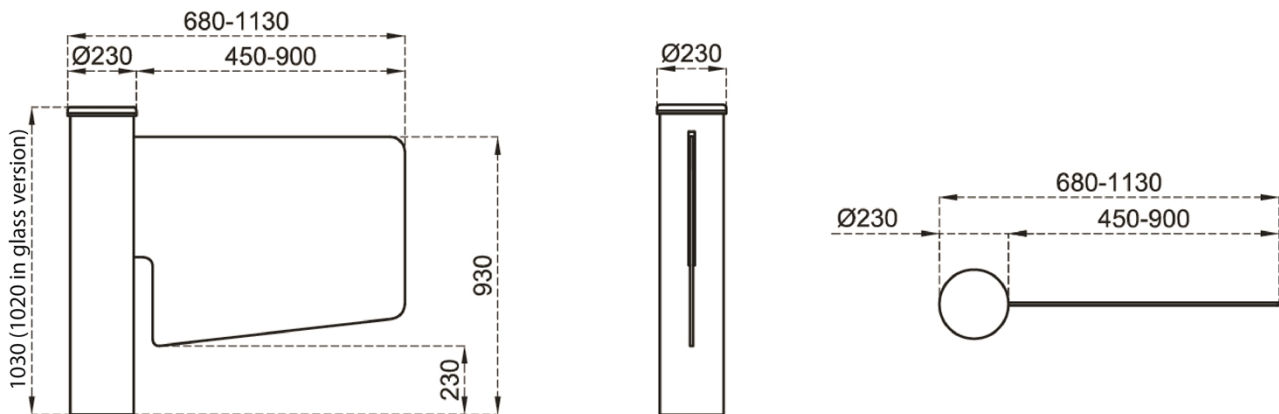

■ Power Requirements	: 110/220-240V. 60/50Hz. AC (%±10) 24V.DC at standby ~2W.max. ~65W.
■ Dimensions	: Cylindrical body 1030mm (1020 with glass top lid) x Ø230mm + Wing width (550 / 900mm)
■ Body Features	: Single piece 304-grade (Opt. 316-grade) satin finished and circular stainless steel body.
■ Wing Features	: Wing is made of 10 mm thick tempered glass (Opt. polycarbon or acrylic). 550 mm or 900 mm wing lengths are available as standard choices.
■ Top Lid Features	: Standard 10 mm thick tempered glass or 20 mm thick natural granite (star galaxy black) stone top lid for a decorative and aesthetical appearance (opt. 20 mm stainless steel or other materials).
■ Indicator Features	: Built-in circular RGB LED status indicators are located under granite top lid. Illumination is blue at stand-by; green during authorised passage, flashing red for unauthorised attempts and green for emergency alert mode.
■ Operating Temperature, Humidity, IP Rating, MCBF	: -20°C - +68°C (Opt. -50°C with heater unit) / RH 95% non-condensing / IP 44 Indoor Model (IP 56 option is available for optional pipe wing versions)/ 1M Cycles.

■ Control System

: All inputs are opto-coupler protected. Controlled by dry contact or grounding input. Compatible with all access control systems that provide dry contact or grounding outputs. Optional RS232/RS485/TCP IP control module is available.

■ System Features & Operation

: Bi-directional DC motor driven mechanism with torque and speed adjustments. The system opens the wing in either direction upon receiving contact to allow passage.

■ Emergency Mode

: In case of emergency input, the wing opens in either direction (pre-set direction by internal dip-switch) and the system stays in open position until the emergency input is removed.

Wing can be pushed open manually in either direction in case of a power failure.

■ Wing Speed

: Wing speed is controlled by adjustable PWM controlled motor driver system.

For 900mm Passage Width Tempered Glass Wing:

-Wing Opening Speed: ~3,0 seconds by default, ~2,5 – 3,5 sec. adjustable.

-Wing Closing Speed: ~3,0 seconds by default, ~2,5 – 3,5 sec. adjustable.

For 550mm Passage Width Tempered Glass Wing:

-Wing Opening Speed: ~2,7 seconds by default, ~2,5 – 3,5 sec. adjustable.

-Wing Closing Speed: ~2,7 seconds by default, ~2,5 – 3,5 sec. adjustable.

❖ 90° movement from original position,

■ Standard Features

: Natural granite (Star Galaxy Black) or tempered glass top lid, indicator lights.

■ Optional Accessories and Applications

: Remote control unit, interface unit for PC, RS485, RS232 and LAN, counter, audio-messaging system, base plate, different top lids, separator, card reader pole.

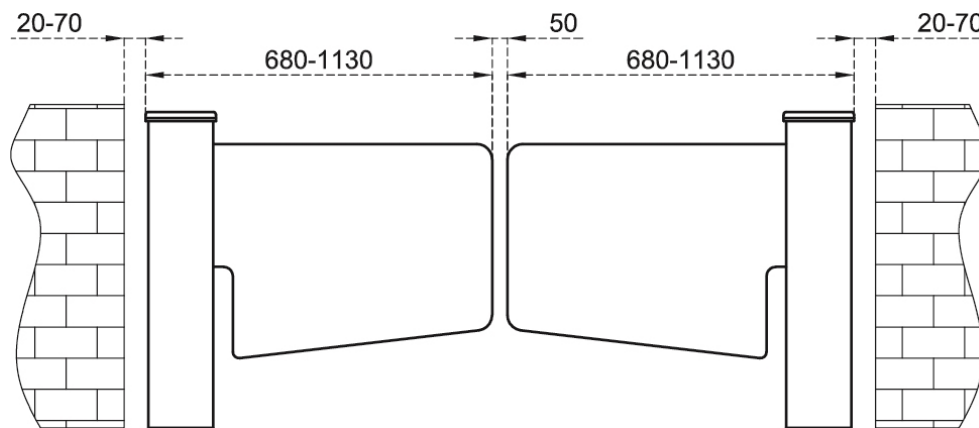

**Design and specifications are subject to change without notice.*