

# SG-L 4233A X-Ray Baggage Scanner

## Product Highlights

- \* Linux operation system
- \* ARM cpu
- \* Digital signal and processor
- \* Working 10000 hours above
- \* Energy saving design
- \* High penetration
- \* Good quality images
- \* One key turn off

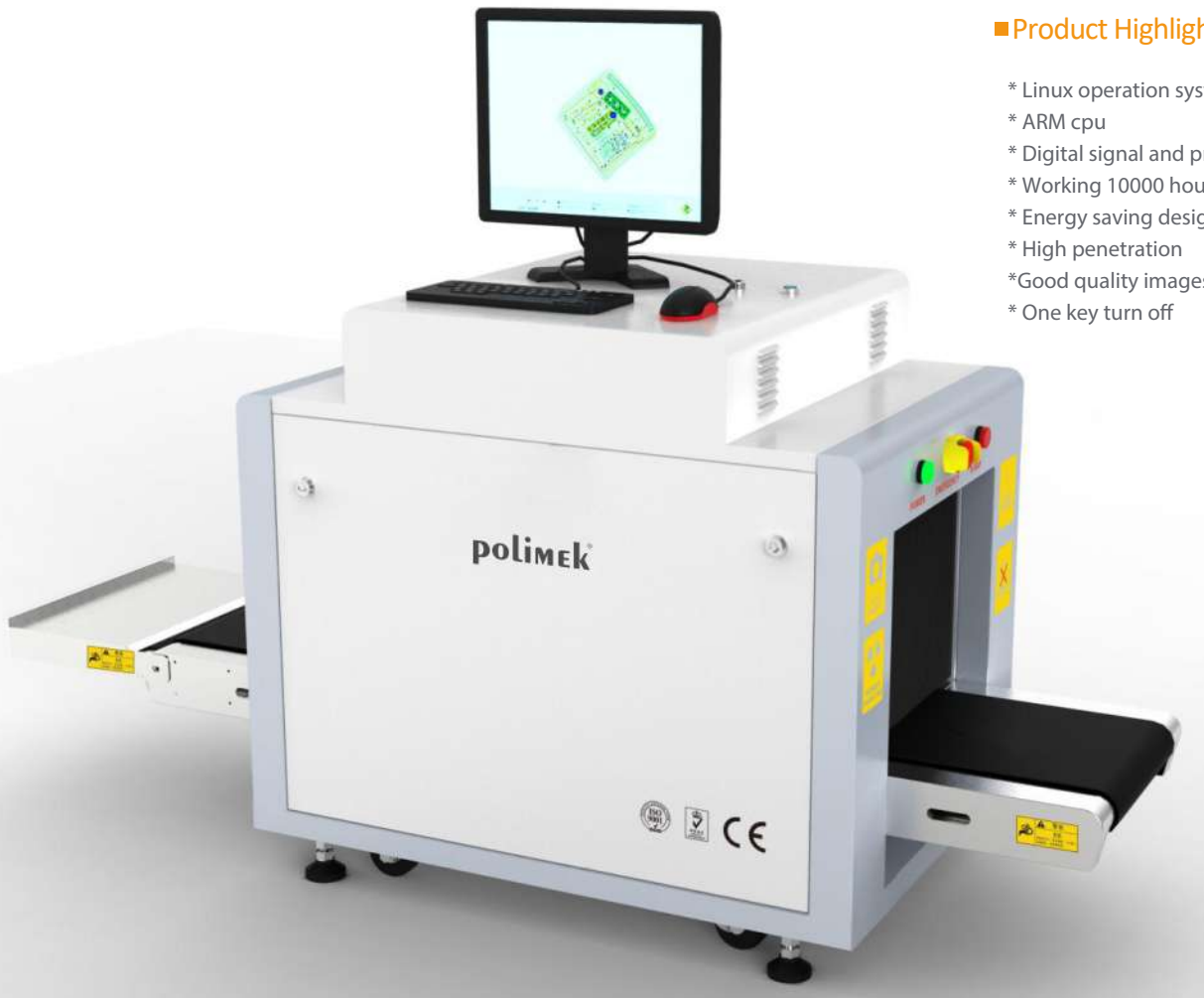

## Dimensional Drawing

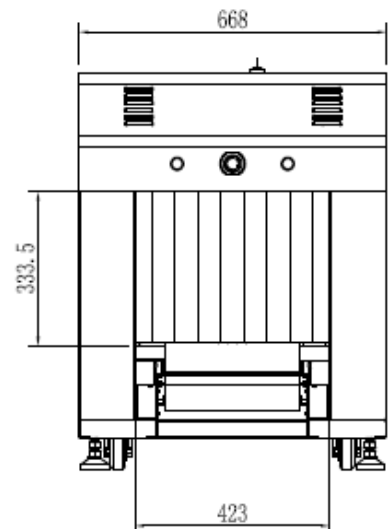
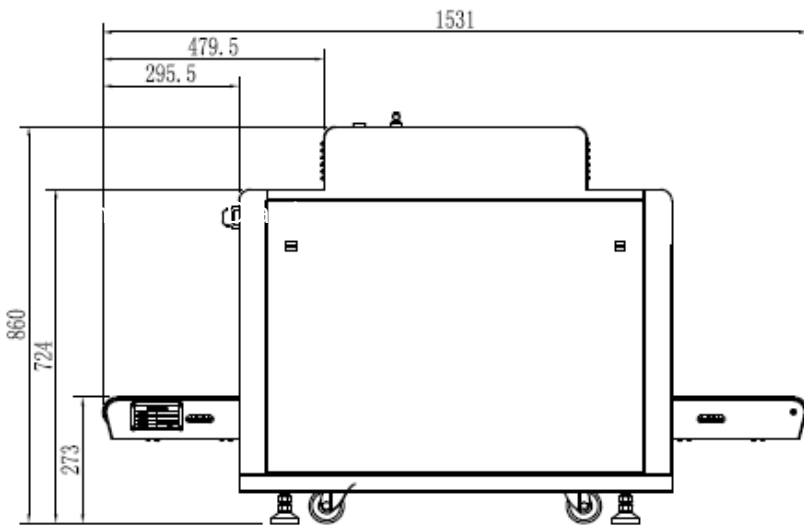

## Important Sizes :

Product Size: 1531\* 668 \* 860mm (L x W x H)

Tunnel Size: 423\*333.5mm (width x height)

## Product Details

### General Specifications

<ul style="list-style-type: none"> <li>■ Wire Resolution</li> <li>■ Penetration resolution</li> <li>■ Spatial resolution</li> <li>■ Penetration</li> <li>■ Resolution of organic matter</li> <li>■ Grayscale and mixture resolution</li> <li>■ Resolution of inorganic objects</li> <li>■ Effective material resolution</li> <li>■ X-Ray dosage each inspection</li> <li>■ Boundary Leakage</li> <li>■ S/N ratio</li> <li>■ Conveyor speed</li> <li>■ Conveyor max load</li> <li>■ Power consumption</li> <li>■ Safety performance requirements</li> <li>■ E M C requirements</li> <li>■ Electrical safety</li> <li>■ Environmental applicability</li> <li>■ Leakage current</li> <li>■ Film Safety</li> <li>■ Weight</li> <li>■ Operation temperature/Humidity</li> <li>■ Storage temperature/Humidity</li> <li>■ Atmospheric pressure</li> <li>■ Operation Power</li> <li>■ Operation system</li> </ul>	<p>Typical AW G 7</p> <p>Typical AW G 12</p> <p>Vertical:1.0mm, horizontal:1.0mm</p> <p>Typical 11mm</p> <p>/</p> <p>/</p> <p>/</p> <p>/</p> <p>≤1.0μSv (uGy)</p> <p>≤0. 5μSv /h(uGy/h)</p> <p>&lt;60dB</p> <p>0.2m/s</p> <p>100kg</p> <p>0.5K W</p> <p>Meet the requirements of G B 15208.1-2005</p> <p>Meet the requirements of G B 15208.1-2005</p> <p>Meet the requirements of G B 15208.1-2005</p> <p>Meet the requirements of G B 15208.1-2005</p> <p>≤5.0mA</p> <p>Guarantee A S A / I S O 1600 Film</p> <p>180kg</p> <p>5°C- 40°C/0%-90%</p> <p>-20°C-60°C /10%-90%</p> <p>86kPa-106kPa A C</p> <p>220V(±10%-15%) 50±3Hz</p> <p>L I N U X</p>
---	---

### General Specifications

<ul style="list-style-type: none"> <li>■ X ray generator</li> <li>■ Electric roller</li> <li>■ Operating</li> <li>■ Monitor</li> <li>■ Operation console</li> </ul>	<p>80 K V, oil cooling, from bottom to top</p> <p>One- phase</p> <p>Hard drive: 500G, Storage : 1G</p> <p>21.5" L E D screen, resolution: 1280*1024 pixels</p> <p>Single screen conso</p>
---	---

### Scanned images

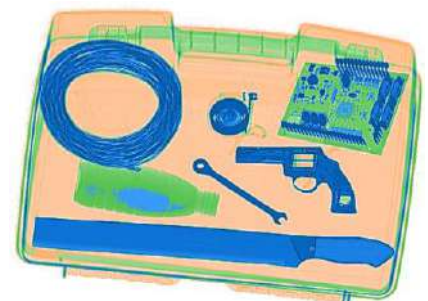
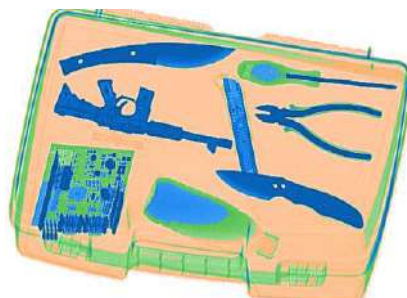
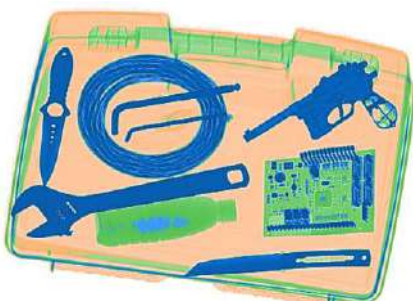

## ■ Functional characteristics

■ Power-on self-test	With the function of fault self-check, automatically judge the fault and prompt the fault code information in time.
■ Image processing	1-64times enlargement continuity. With the function of Color/ B W, negative, high/low penetration, organic /inorganic stripping, general enhancement, and pseudo color, etc.
■ Image Recall	30 preceding images recallable.
■ The number of images stored	Up to 10,00 images stored automatically.
■ Real-time curve	The real-time curve can be used to detect whether the acquisition system and components work normally.
■ Time setting	System time can be set
■ Probe setting	It can realize the manual deletion of the low and low energy detection board dead pixels, and display the deleted dead pixels in the display area.
■ Ray source setting	There are two source and analog source control modes, the source parameters of the digital source can be set.
■ Alarm system	The alarm function can be activated and deactivated, and the alarm type of the alarm box, sound and light alarm can be selected, and the sensitivity, minimum absorption rate, maximum absorption rate, and alarm duration can be set.
■ Troubleshooting	It can realize whether the components such as the entrance and exit light barrier, side panel switch, emergency stop switch and light source are normal, and display the standard value and current value of the detection voltage
■ Image setting	The drum running control direction and the image display moving direction can be set.
■ Software registration	It can realize software registration function and has serial number, registration code, registration status and system time information display.
■ User login	Log in by entering different user name and passwords , only when logging in can you make other settings.
■ User management	You can add, delete, edit the user name and password , set the user level to restore the deleted user.
■ Authority management	Different default permissions can be set according to user level.
■ Language settings	The system language can be set to switch between Chinese and English.
■ Log management	User operations can be monitored to query user actions.
■ About	The version and device number can be displayed.
■ TIP report	The report can be generated by the tip operation after the tip insertion function is turned on, and the content of the report: user name, number of tip insertions, number of tags, false positive rate, probability of detection, probability of false positives.
■ Tip management	It can be set to enable and disable the insertion of dangerous goods, and can set the identification time, Prompt time, insertion frequency, proportion of single items inserted into dangerous goods add tip files and delete files.
■ Document management	It can query, open, and export the checked image.
■ Function setting	It can set log level, save the file time, whether to open the training function and setting the smart roller.
■ Data setting	Display system working hours, the total working hours of the ray source, the total number of system baggage and packages, and the total number of baggage packages this time, and clear the above data.
■ System parameter setting	It can select the exported data, pictures, and backup directory, select and adjust the motor type, detector type, whether to enable the debug mode, model, and gain , enter the corresponding IP address on network connection to realize sharing function, and have corresponding software to achieve system upgrade.

## ■ Compliance

■ International	*ISO19001 ; SO14001 ; ISO27001; OHSMS18001 ; CE , ROHS , FCC , REACH , USA , FDA
■ National	*Health Inspection Report *Computer Software Copyright Registration Certificate *Software Product Registration Certificate *Radiation Safety Certificate from Ministry of Public Security *Quality Certification from Safety and Police Electronic Products Quality Inspection Center *Design patent certificatio