

PL 001 SWING GATE TURNSTILES

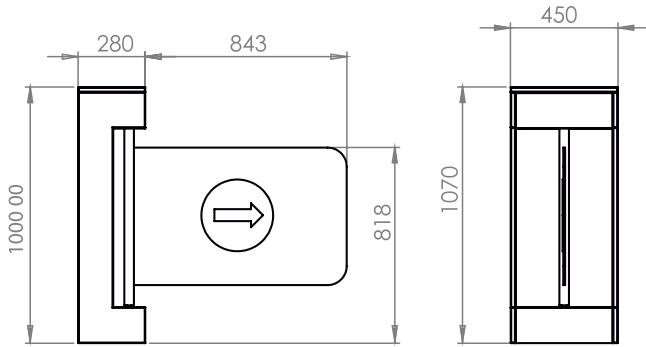

Product Specifications: Stainless Steel, painted

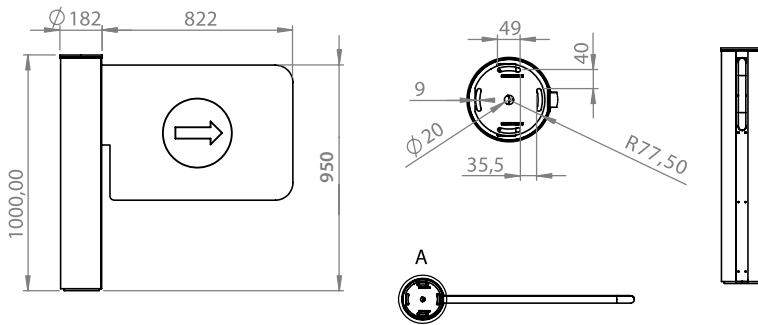

Product Specifications: Stainless Steel, painted



Technical Specifications

Operation: Bi-directional motor wing
 Body: 1.2 mm thick stainless steel.
 Wing: 10 mm tempered plexiglass
 IP Class: IP54 (Op. IP56)
 Operating Temperature: Between (-20°C) and (+68°C) Op: -50°C with heater.
 Functions:
 Switching time adjustable, adjustable switching directions, audible alarm
 Emergency: In case of all kinds of disasters and emergencies, wing can be open in either directions automatically.
 Power Supply: 110/220V – 50/60 Hz AC (%10 +-)
 Power Consumption: 24V DC standby 12W max 60W 7W max 14W. Power supply system (SMPS) with the feature of filtering fluctuations likely to occur in electrical lines
 Opening-Closing Speed: 2 second
 Transition Range: 900 mm
 Safety Level: Deterrent
 Indicators: Bidirectional double colour led panel
 Accessories: Logo engraving on wings. Sticker. Remote control unit. Reader apparatus.
 Control System: Compatible with all kinds of Access control units and token systems. Opt. Functions can be controlled with RS232-485 or LAN (network)